

MULTI-FLO

MULTI-FLO WASTEWATER TREATMENT SYSTEMS

DESIGN MANUAL

Revised December 19, 2003

Consolidated Treatment Systems, Inc.

1501 Commerce Center Drive

Franklin, OH 45005

937-746-2727

www.multi-flo.com

Multi-Flo -Series Onsite Wastewater Treatment Systems

Introduction

Onsite wastewater treatment refers to the process of treating and disposing, dispersing, or recycling of wastewater at or near its point of generation. Historically, the phrase has been synonymous with “septic system” because that was the only design alternative available. With the advent of different design technologies, septic systems are just one of several available alternatives. Because treated wastewater—effluent—is a valuable resource, owners have the flexibility in how they use this resource. Multi-Flo systems provide owners with options as to how they treat and recycle wastewater.

The suitability and design of septic systems rely upon native soils to treat *and* disperse wastewater. In fact, treatment and dispersal are essentially combined in the same process. For this reason, septic system use is limited to those soils where both functions can be accomplished. Multi-Flo units allow owners to separate treatment and dispersal and address each separately. If soil is the selected dispersal alternative, the design can be based solely upon the ability of the soil to transmit water from the site. Owners may have options, depending on local codes, to use the treated wastewater for beneficial purposes such as recycling into plumbing systems or irrigating gardens and turf. The Multi-Flo series provides owners with alternatives unavailable to those who rely solely upon septic systems.

The Multi-Flo -series are capable of treating typical domestic wastewater daily flows equal to rated capacities, which are shown in Table 1. The Multi-Flo FTB-series design is based on the same principles as many municipal wastewater treatment plants. These design principles have been adapted for the small flows developed by individual residences or small commercial/residential developments.

Model	Rated Flow (gpd)	O ₂ Transfer (Max., lb/day)
FTB-0.5	500	3.6
FTB-0.6	600	3.6
FTB-0.75	750	3.6
FTB-1.0	1000	7.2
FTB-1.5	1500	10.8

This manual serves as a guide to design an onsite wastewater treatment system using Multi-Flo units. The manual includes recommendations for both residential and commercial applications. The recommendations include typical flow data and component suggestions. A failure to consider these recommendations may result in poor unit operation or additional maintenance.

Definitions

The following definitions are critical to understanding the design, installation and operation of Multi-Flo units. These definitions have been purposely simplified so they can be understood by a wide range of readers.

ANSI/NSF Standard 40: A performance certification standard intended for onsite wastewater treatment systems having a flow for between 400 and 1500 gpd (gallons per day) and a single point of discharge.

CBOD₅: The concentration of oxygen (expressed as mg/L) utilized by microorganisms in the non-nitrogenous oxidation of organic matter during a five-day period at a temperature of 20°C.

Clarify: A process of separating from wastewater fats, oils, grease, and floatable materials, which float to the surface; and solids, which sink to the bottom.

Commercial Occupancy: A building used for commerce or industry.

Dispersal: A process for recycling treated wastewater back into the environment.

Dosing: A process for periodic discharge of wastewater to a Multi-Flo unit.

Effluent: The discharge from a treatment component or system.

Flow Equalization: A process for mitigating variations in flow by holding wastewater in a tank and dosing the wastewater into the Multi-Flo unit.

Flow Equalization Tank: A watertight, airtight tank, timer, and pumping system having a detention time of 16-to-24 hours used to capture and retain solids, grit, and scum, and then meter the water into the Multi-Flo unit through periodic dosing.

FOG: Fats, oils, and grease in wastewater.

Frequenter: A visitor to and/or customer of a commercial occupancy.

Grease Trap: A tank for capturing and retaining fats, oil, and grease.

Maintenance: Periodic activities intended to maintain the efficiency and effectiveness of the system.

Mixed Liquor. The contents of the Multi-Flo aeration chamber consisting of, but not limited to, partially treated wastewater and microbial colonies that oxidize the organic material in the wastewater.

Onsite Wastewater Treatment System. A device or combination of devices, which may include tanks, vessels, pumps, aerators, aerators, and other mechanical equipment, intended to treat and disperse wastewater at or near the point of generation.

Pre-aeration: Aeration of wastewater to reduce the CBOD₅ prior to discharge to the Multi-Flo unit.

Pre-Aeration Tank: A tank used to reduce partially the CBOD₅ of the wastewater before the wastewater enters the Multi-Flo unit.

Pretreatment Tank: A watertight, airtight tank having a detention time from 12-to-24 hours used to capture and retain solids, grit, and scum before the wastewater enters the Multi-Flo unit.

Residential Occupancy: A building used to house individuals and families.

Septic System: An onsite wastewater treatment system comprised of a septic tank and soil absorption system.

Septic Tank: A watertight, airtight tank having a detention time of 24-to-48 hours, or more, used to clarify wastewater and capture fats, oil, greases, and inert solids.

Soil Absorption System: A system consisting of trenches and pipes—or equivalent “gravelless” devices—used to disperse water into the soil where additional treatment may occur and the water is dispersed from the site.

Trash Trap: A watertight, airtight tank for capturing and retaining solids.

Seeding: A process for facilitating bacterial growth by providing mixed liquor from another Multi-Flo unit.

TKN (Total Kjeldahl Nitrogen): The quantity of organic nitrogen and ammonia (expressed in mg/L) found in wastewater.

TN: The total quantity of nitrogen (expressed in mg/L-N) that exists in the wastewater. Nitrogen may be in the form of ammonia, TKN, nitrate or nitrite.

TSS: The quantity of solids (expressed in mg/L) that can be readily removed from a well-mixed sample with standard laboratory filtering procedures.

Typical Domestic Wastewater: Wastewater having the characteristics as shown in Table 2:

Constituent	Value
CBOD5	100-300 mg/L
TSS	100-350 mg/L
FOG	30 mg/L
TKN	60 mg/L

Wastewater: Water generated as a result of human activities and containing feces, urine, blood, food byproducts, rinse water, laundry water, process water, and the like.

Design Principles

The goal of wastewater treatment is to return to the environment water that does not pose a public health or environmental threat. The role of the Multi-Flo in this process is to remove organic materials, solids, and pathogens through biological treatment.

Each model of the Multi-Flo FTB-Series has a specific design rating. Each rating is intended to identify the volume of typical domestic wastewater that the system can treat in a 24-hour period. The flow during this 24-hour period, as tested under ANSI/NSF Standard 40, is shown in Table 3.

Time of Day	Percent of Total Hydraulic Load
6:00 AM-9:00 AM	35
11:00 AM-2:00 PM	25
5:00 PM-8:00 PM	40

Additional treatment may be necessary where the flow regime varies from Table 3 and/or the wastewater does not meet the criteria of typical domestic wastewater.

Typical domestic wastewater may include small quantities of medicines, cleaners, antibiotics, and other substances that, in large quantities, will adversely affect the operation of the system. The water will have a pH of approximately 7.0 and may have minute concentrations of heavy metals. If the pH is above 9.0 or less than 6.0, and/or there are high concentrations of harmful substances and heavy metals, additional treatment will be necessary.

Depending on the occupancy, an additional tank may be installed upstream of the Multi-Flo. This additional component may be a "trash trap," "pretreatment tank," "flow equalization tank," or "pre-aeration tank." The name will vary with the intended function of the tank, and the function of the tank is related to its capacity and components. A trash trap is the smallest of these, and its function is simply to capture and retain large solids such as tampons, disposable diapers, and so forth. No additional treatment or function is expected, and the capacity of the tank may be as small as 250 gallons.

A pretreatment tank is larger than a trash trap, and its function is to capture and retain fats, oils, grease, and smaller solids such as dental floss. The capacity of a pretreatment tank is related to the flow from the occupancy. A flow equalization tank serves as a pretreatment tank, but its primary function is to retain wastewater for periodic dosing into the Multi-Flo. A pre-aeration tank is intended to provide additional oxidation. This tank will contain additional aerators to facilitate a partial digestion of organic material prior to its discharge to the Multi-Flo unit. A pre-aeration tank may also serve as a flow equalization tank.

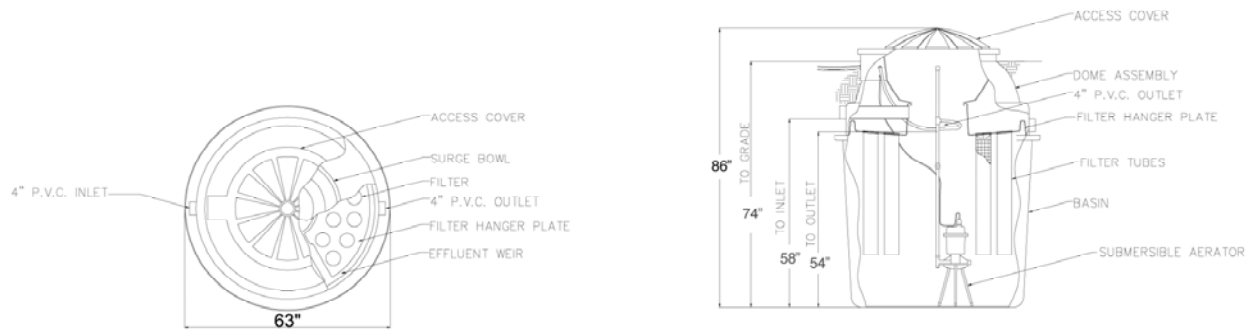

Figure 1—Multi-Flo FTB-0.5

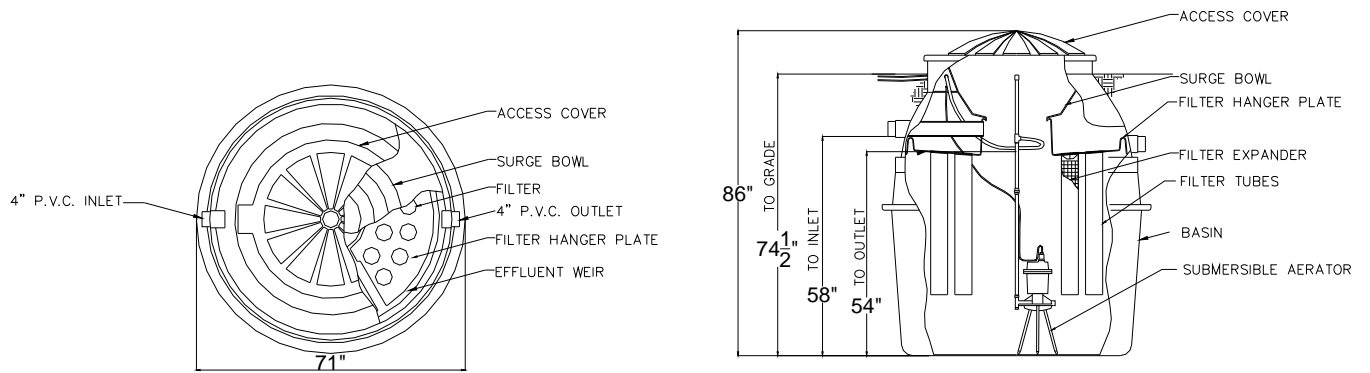

Figure 2—Multi-Flo FTB-0.6

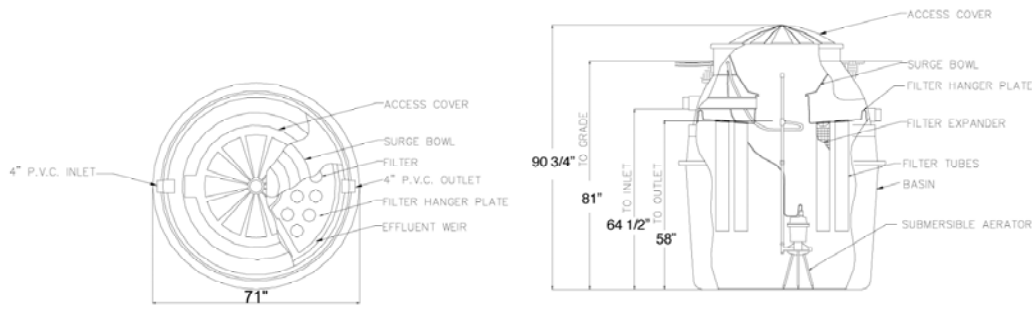

Figure 3—Multi-Flo FTB-0.75

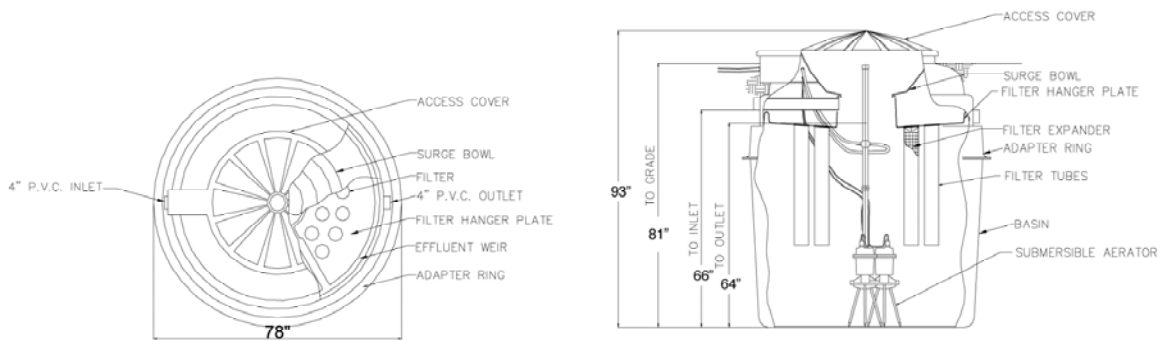

Figure 4—Multi-Flo FTB-1.0

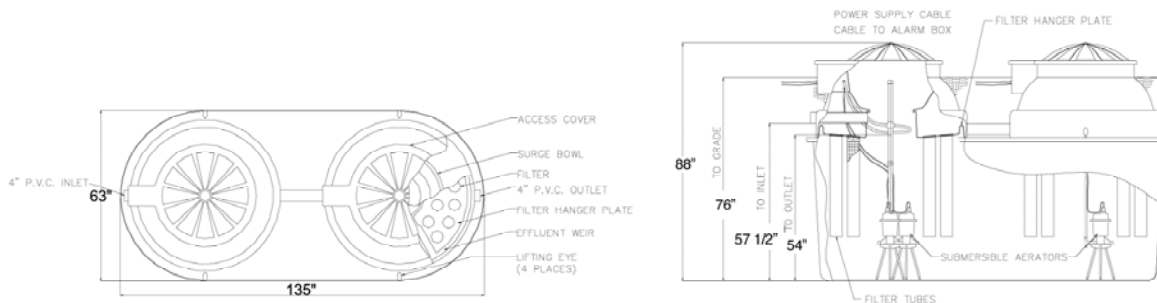

Figure 5—Multi-Flo FTB-1.5

Every county of almost every state regulates the design, installation, operation, and maintenance of onsite wastewater treatment systems. Some counties have few regulations while others maintain comprehensive programs that include licensing, certifications, plan review, and mandatory maintenance. Generally, these regulations mandate residential system sizing, usually based on the number of bedrooms. Commercial occupancies generally use building code parameters to establish design flow. These parameters are based on number of patrons, square footage of retail space, restaurant seats, and other indicators of potential wastewater generation. Some codes may consider alternative values to establish flow, such as actual water use for similar facilities, but most codes are prescriptive in setting design flows.

Listed in Table 4 are recommended sizing and components for single-family dwellings based on a design flow of 150 gpd/bedroom.

Multi-family occupancies are more susceptible to abuse by tenants, who may be unaware that they are using onsite wastewater treatment. For these occupancies, a pretreatment tank may eliminate maintenance issues related to grease and solids put into the system. Table 5, which is based on a flow of 150 gpd/bedroom, illustrates recommended components, volumes, and ratings for multiple family dwellings.

Number of Bedrooms	Garbage Disposal?	Recommended Size of Pretreatment Tank	Required Capacity of Multi-Flo (gpd)
1-2	No	Optional	500 gpd
1-2	Yes	Optional	500 gpd
3	No	Optional	500 gpd
3	Yes	Optional	500 gpd
4	No	Optional	600 gpd
4	Yes	Optional	600 gpd
5	No	Optional	750 gpd
5	Yes	500 gallon	750 gpd

Number of Bedrooms Served	Recommended Size of Pretreatment Tank if needed, (gal)	Required Capacity of Multi-Flo (gpd)
1	Optional	500
2	500	500
3	500	500
4	500	600
5	500	750
6	750	1000
7	750	1200
8	750	1200
9	750	1500
10	1000	1500

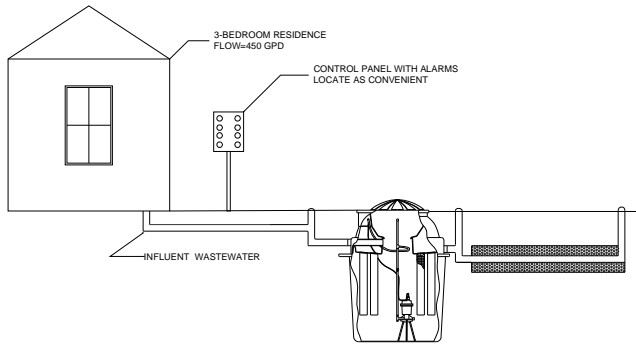

Figure 7 - Basic Multi-Flo Installation

Figure 7 shows a basic installation. In this example, the Multi-Flo FTB-0.5 serves a three-bedroom residence. It receives and discharges flow by gravity. Effluent is dispersed through a drainfield sized in accordance with applicable codes. In this example, the Multi-Flo provides both the storage of a septic tank and wastewater treatment normally associated with the drainfield. The soil acts to “polish” the effluent of residual pathogens, solids, and organic material.

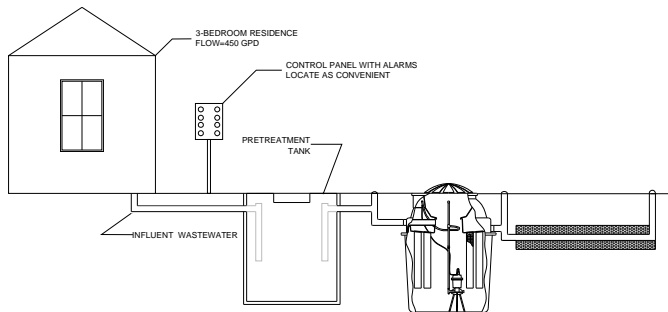

Figure 8 - Multi-Flo Installation With Pre-Treatment

Figure 8 shows a basic Multi-Flo installation with the addition of a pretreatment tank. “Pretreatment” is essential when the wastewater is laden with solids or has other unusual characteristics. Pretreatment accomplishes several functions: capture and storage of solids, homogenization of the wastewater, and partial removal of organic material. Pretreatment may enhance treatment is generally not essential for successful performance.

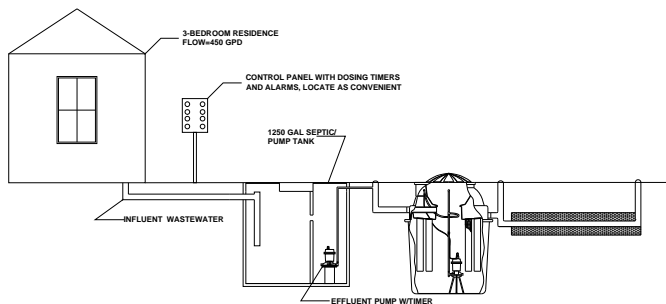

Figure 9 - Multi-Flo Installation With Flow Equalization

Flow equalization may be needed when high variation exists. Such cases arise when much or all of the flow is generated during one or two short periods of a day or week. As an extreme example, flow equalization would help when all wastewater is generated in the morning and evening, there are parties on Friday evenings, and all laundry is washed on Saturdays. Flow equalization provides a method to capture, homogenize, and meter wastewater into the Multi-Flo,

maximizing operational efficiency.

Flow equalization functions by placing a pump on a timer that operates over a 24-hour cycle. The design flow will be divided into 48 or 96 equal doses, each of which will be discharged at 15-to-30 minute intervals, depending on the design. For example, a 500 gpd FTB-0.5 can receive 48 doses of about 10.4 gallons, each dose discharged at 30-minute intervals.

Flow equalization also provides the benefits of pretreatment. As shown in Figure 9, the flow equalization tank is actually a two-compartment septic tank-pump chamber. The septic tank portion acts as a pretreatment tank while the pump chamber holds partially treated water for dosing into the Multi-Flo.

Design Requirements for Commercial Occupancies

Although the Multi-Flo has been used primarily for residential facilities, including both single-family and multiple-family dwellings, Multi-Flo can be effectively used for commercial occupancy including various types of food services. Because of hydraulic surges, grease, use of chemicals and cleaning agents, additional pre-treatment facilities may be required when the Multi-Flo is used for certain types of commercial facilities.

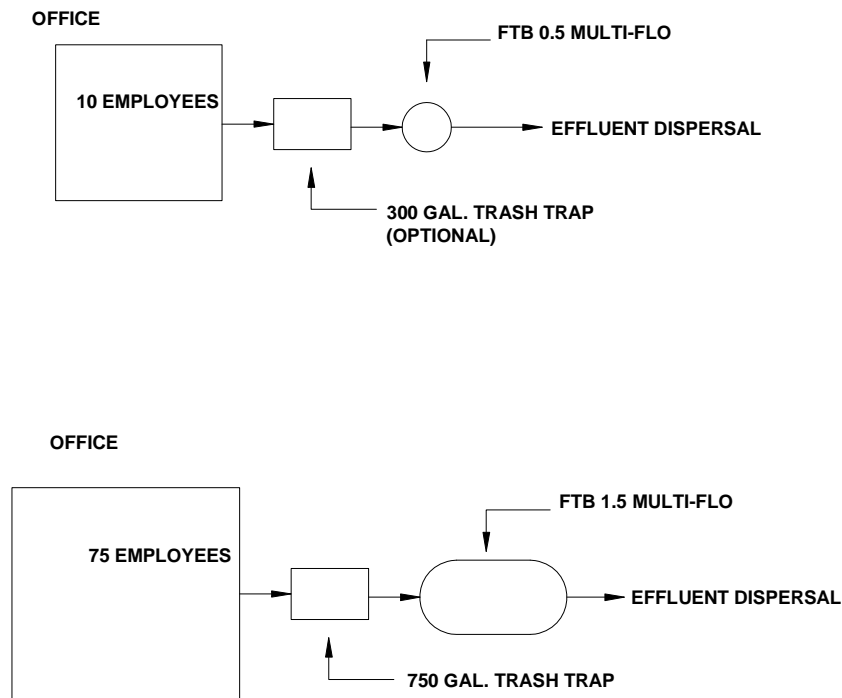

Figure 10—Commercial Occupancy Multi-Flo Installation with Flow Equalization

Design Flow and Loads

Essential to proper design of commercial systems is a characterization of the flow and organic and solids loadings the occupancy will generate. These values may be obtained from several sources. If the facility is existing, meter readings may provide the answers. For new facilities, design values may already be established in plumbing or sanitary codes. Standard engineering texts also provide values. Listed below in Table 6 are typical design values.

Table 6—Wastewater Flow and Organic Load			
Type of Facility	Flow Gal/Unit/Day	CBOD₅ mg/L	CBOD₅ lb/DAY/UNIT
Apartment	150 gal/bedroom	240	.30 lb/bedroom
Assembly Hall (no kitchen)	5 gal/seat	240	.01 lb/seat
Bowling Alley (no kitchen)	75 gal/lane	240	.15 lb/lane
Church (no kitchen)	3 gal/sanctuary seat	240	.01 lb/seat
Country Club	50 gal/member	400	.17 lb/member
Country Club	20 gal/employee	240	.04 lb/employee
Drive-In Theaters	5 gal/car space	240	.01 lb/car space
Employee (no showers)	20 gal/employee	240	.04 lb/employee
Employee (showers)	35 gal/employee	240	.07 lb/employee
Food Service			
Ordinary Restaurant	50 gal/seat	600-800	.35 lb/seat
24-Hour Restaurant	75 gal/seat	600-800	.50 lb/seat
Freeway Restaurant	100 gal/seat	600-800	.70 lb/seat
Tavern (limited food)	30 gal/seat	400	.10 lb/seat
Carry-out (single-service)	50 gal/100 sq.ft./floor sp.	600-800	.70 lb/100 sq.ft./fl. sp.
Carry-out	20 gal/employee (add'l)	240	.04 lb/employee
Fast Food Chain	100 gal/seat	1000	.80 lb/seat
Hospital (not incl. Personnel)	200 gal/bed	400	.70 lb/bed
Hospital personnel (additional)	20 gal/employee	240	.04 lb/employee
Laundry (coin-operated)	400 gal/machine	600	2.00 lb/machine
Mobile Home Park	200 gal/space	240	.40 lb/space
Motel and Hotel, regular	150 gal/room	240	.30 lb/room
Resort hotel, cottage	75 gal/room	240	.15 lb/room
Add for self-service laundry	400 gal/machine	600	2.00 lb/machine
Nursing Home (not incl. Kitchen or laundry)	100 gal/bed	400	.30 lb/bed
Office Building (per 8-hr shift)	20 gal/employee	240	.04 lb/employee
Service Station	250 gal/water closet	240	.50 lb/fixture
Schools			
Day/type	15 gal/student	240	.03 lb/student
Add for showers	5 gal/student	240	.01 lb/student
Add for cafeteria	5 gal/meal	600	.03 lb/meal
Add for school employees	15 gal/employee	240	.03 lb/employee
Boarding school	75 gal/student	240	.15 lb/student
Shopping Center (no food)	100 gal/1000 sq.ft./floor sp	400	.30 lb/1000 sq.ft.fl.sp.

Type of Facility	Flow Gal/Unit/Day	CBOD ₅ mg/L	CBOD ₅ lb/DAY/UNIT
service or laundry)			
Travel Trailer or RV Park			
W/out water/sewer hook-up	75 gal/space	400	.25 lb/space
With water/sewer	100 gal/space	400	.30 lb/space

Four flows must be considered during the design: maximum month average daily flow, minimum monthly average daily flow, peak daily flow, and peak hourly flow. Each of these will be different, and the combination of these flows is essential developing the most efficient design. Typically, the Multi-Flo unit will be sized to treat the maximum month average daily flow. If there are multiple Multi-Flo units operating in parallel, they will be placed into service depending on how the flow varies over a year's time. Flow equalization must be sized to hold the peak daily flow. And if the peak hourly flow is high, flow equalization must be sufficient to hold this additional flow above the peak daily flow.

Ideally, flow should be spread over a 24-hour period. The minimum effective capacity of the treatment tank should be two-thirds the peak daily flow. Churches and meeting halls may have only one or two days each week during which they are in use. Flow equalization may spread the large single-day flows over two or three days, depending on the maximum month average daily flow.

When flow equalization is used, a separate trash trap is generally not needed. For greater efficiency, a two-compartment septic tank should be considered for use as the flow equalization tank

The size and pumping frequency of the pump depends upon the volume of wastewater to be treated. Typically, an 11-gallon dose is given over a five-minute interval. Such low loading minimizes the need for larger pumps. The following table gives recommended pumping frequency and volume/dose:

Flow (gal/day)	Doses/Day	Gal/Dose
250	24	11
500	48	11
750	72	11
1000	96	11
1500	96	16

For food service occupancies, grease traps will also be required. The capacities of these grease traps may be set in local plumbing codes. Generally, the minimum capacity is 750 gallons. When the required capacity exceeds 1000 gallons, two or more tanks located in series should be considered. Only plumbing fixtures located in the kitchen should be connected to the grease trap.

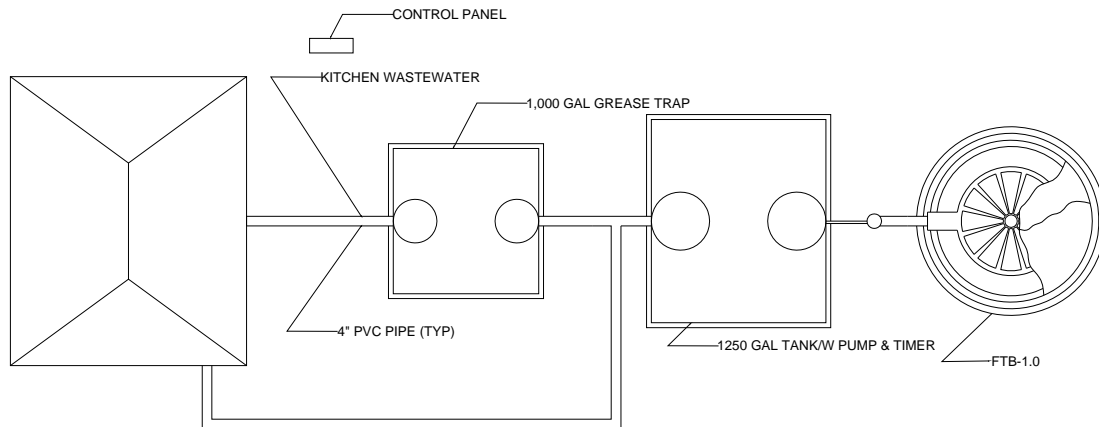

Figure 11—Plan View Showing Grease Trap

Even if flow equalization and a grease trap are not required, a trash trap is recommended to capture fats, oil, grease, and other material from entering the Multi-Flo. Such material includes, but is not limited to, tampons, sanitary napkins, cleansing pads, contraceptives, dental floss, and so forth.

The following recommendations address designs for different applications:

- **Single Family Residence:** A trash trap is optional unless a garbage disposal is installed. If a trash trap is provided, it should have a capacity of 300-to-500 gallons.
- **Rental Housing, Multiple Family or Mobile Home Parks:** A trash trap having a capacity of 50 percent of the average daily flow should be provided.
- **Offices and Public Buildings without Kitchen Facilities:** A small trash trap with a capacity of 25-to-50 percent of the daily average flow should be provided. Although such facilities do not have a grease problem, they do frequently experience problems with paper towels and sanitary napkins. It may be advisable for the owner to use wall-mounted hand dryers or cloth towel dispensers.
- **Gas Stations, Garages or Auto Repair Shops:** A trash trap having a capacity of 50 percent of the average daily flow should be provided. Under no circumstances should wash bays, floor drains or oil separators be connected to the Multi-Flo.
- **Campgrounds:** A trash trap with a capacity of 50 percent of the daily flow should be installed. It is not advisable to discharge the contents of the dump station into the Multi-Flo since there is usually a large amount of bacterial retardants and other chemicals that may kill off the bacteria in the Multi-Flo.
- **Weekend Cottages or Winter Homes:** Facilities with small daily flows, intermittent or seasonal usage should not have a trash trap installed.

- **Restaurants, Hospitals, Nursing Homes or Schools:** Facilities having kitchen and laundry facilities require trash traps or grease traps. Contact your Multi-Flo representative for specific recommendations on the design of systems to serve the above types of facilities.
- **Facilities Served By Two Or More Multi-Flo Plants in Parallel:** Provide a trash trap before a distribution box if the flow is to be split between two or more Multi-Flo units.

The treatment capacity of each Multi-Flo unit is based upon the oxygen requirements necessary to treat typical domestic wastewater. The Multi-Flo aerator is designed to treat a minimum of 1.5 lb-CBOD₅/day. Where wastewater has a higher organic concentration, additional oxidation capacity will be required. Often this additional capacity is provided by adding aeration to the pretreatment tank. For example, foodservice wastewater frequently has a CBOD₅ greater than 1000 mg/L due to soluble grease, cleaning agents, etc. Because of the higher oxygen demand, a longer retention in the aeration stages is required. Pre-aeration meets the additional oxygen requirements. Pre-aeration can usually be accomplished by installing one or more Multi-Flo aerators in either the grease trap or trash trap.

Pre-aeration provides benefits beyond oxidation. Some chemicals may be volatilized or directly oxidized by exposure to oxygen. Air aids in cooling and emulsifying fats, oil and grease so that they float to the surface. Generally, the wastewater will be homogenized so that the Multi-Flo does not experience sudden changes in wastewater character.

The microbes that perform the wastewater treatment occur naturally. When operation starts, bacteria takes from six-to-eight weeks to acclimate themselves to the wastewater and colonize in sufficient concentration that measurable treatment occurs. "Seeding" can be used to eliminate this start-up performance lag. Seeding is accomplished by obtaining about 50 gallons of mixed liquor from another Multi-Flo unit. The already-acclimated, concentrated colony should experience no delay in acclimating to the new unit so that a performance lag may be circumvented.

Cellular activity varies with the temperature. Microbes are less active in the winter, so seeding is essential for winter-time startup.

Table 8 should be used to determine the minimum hydraulic capacity of Multi-Flo systems to serve commercial facilities that do not have kitchen or laundry wastes. In some cases, pretreatment facilities may be required if average wastewater strength exceeds 300 mg/L CBOD₅ or if large volumes of wastewater are generated during peak periods. Whenever the daily wastewater flow is great enough to require more than one Multi-Flo unit, flow splitting should be used for even flow between or among units. Multi-Flo are not operated in series, nor should the flow be split between or among units of different capacities.

Please contact our local factory representative to determine if additional facilities may be required.

Average Daily Flow	Recommended Size of Pretreatment-Tank	Multi-Flo Unit(s)
0 – 500 gpd	300 gallon	FTB-0.5
501 – 600 gpd	300 gallon	FTB-0.6
601 – 750 gpd	500 gallon	FTB-0.75
751 – 1000 gpd	500 gallon	FTB-1.0
1001 – 1200 gpd	750 gallon	Two FTB-0.6
1201 – 1500 gpd	1000 gallon	FTB-1.5
1501 – 2000 gpd	1000 gallon	Two FTB-1.0
2001 – 2250 gpd	1000 gallon	Three FTB-0.75
2251 – 3000 gpd	1500 gallon	Two FTB-1.5
3001 – 4500 gpd	2000 gallon	Three FTB-1.5
4501 – 6000 gpd	2000 gallon	Four FTB-1.5

In designing a system for a commercial occupancy, the designer should consider the following:

- Maximum Month Average Daily Flow
- Minimum Month Average Daily Flow
- Peak Daily Flow
- Peak Hourly Flow
- Concentration and Mass of CBOD₅ for Flows
- Concentration and Mass of TSS for Flows

Operation and Maintenance Procedures for Seasonal or Intermittent Use Facilities

Frequently, Multi-Flo systems are installed at facilities that are used intermittently or seasonally. Because of the reduced or sporadic loading that these installations receive, the routine service and maintenance requirements are different from that normally expected of a year-round residence. The following recommendations are for the operation and maintenance of both residential and commercial systems that will not be operated on a full-time basis.

Seasonal Facilities are characterized by regular usage for several consecutive months, followed by several months during which no flow enters the unit. If the periods of non-use exceed three months, the Multi-Flo should be shut down and “winterized” by the following procedures:

- 1) Disconnect the unit at the breaker box and unplug alarm.
- 2) Completely pump out all sludge and liquids from the basin.
- 3) Flush and clean effluent filters, if installed, and Multi-Flo filter “socks.”
- 4) Fill unit with clean water.

- 5) Take the aerator out of the unit and clean it by lightly coating it with oil to prevent rusting. Store the aerator upright until the next season operation resumes.

Upon resuming normal use, install the aerator, plug in the alarm, re-connect the unit at the breaker box, and seed the unit. Winterizing and start-up should be performed by an authorized Multi-Flo distributor to insure proper operation of the system.

Intermittent use facilities are characterized by periodic occupancy followed by periods of vacancy. Typically, the vacancy will not last longer than three months. If the unit will be unused for less than three months, timed aeration may be better. Timed aeration consists of connecting the aerator to a timer that limits aeration operation at from two-to-four hours daily. Timed aeration will prevent anaerobic conditions and reduce the power consumption.

- 1) Weekend use: If the system will be used for short periods but on a regular basis (i.e., every weekend throughout the year), timed aeration may be provided during periods of non-use.
- 2) Vacation homes: If the system will be used for several weeks followed by several months of vacancy, the Multi-Flo may be shut off during vacancies. Pumping is generally unnecessary. If possible, the Multi-Flo should be allowed to run a few days after flow has stopped to oxidize any remaining organic material. As a part of start-up, the Multi-Flo distributor should check the unit to insure that the system is operational.

During periods of occupancy, the Multi-Flo unit must be operated in accordance with the manufacturer's recommendations and NSF certification.

During start-up, units may be prone to "sudsing," which is the production of foam from laundry detergents. Laundering should be limited during this period.

Where freezing is a danger, the Multi-Flo should be pumped during vacancies. Where uplift is a possibility, the uplift restraint must be provided.

Design Examples

Examples 1, 2, and 3: Residential Occupancies—Residential occupancies are generally designed based on the number of bedrooms, the daily flow assigned for each bedroom. Figure 12 shows typical layouts for single- and multiple-family dwellings. A trash trap is generally optional for single-family, owner-occupied dwellings. A trash trap is advisable for all rental property.

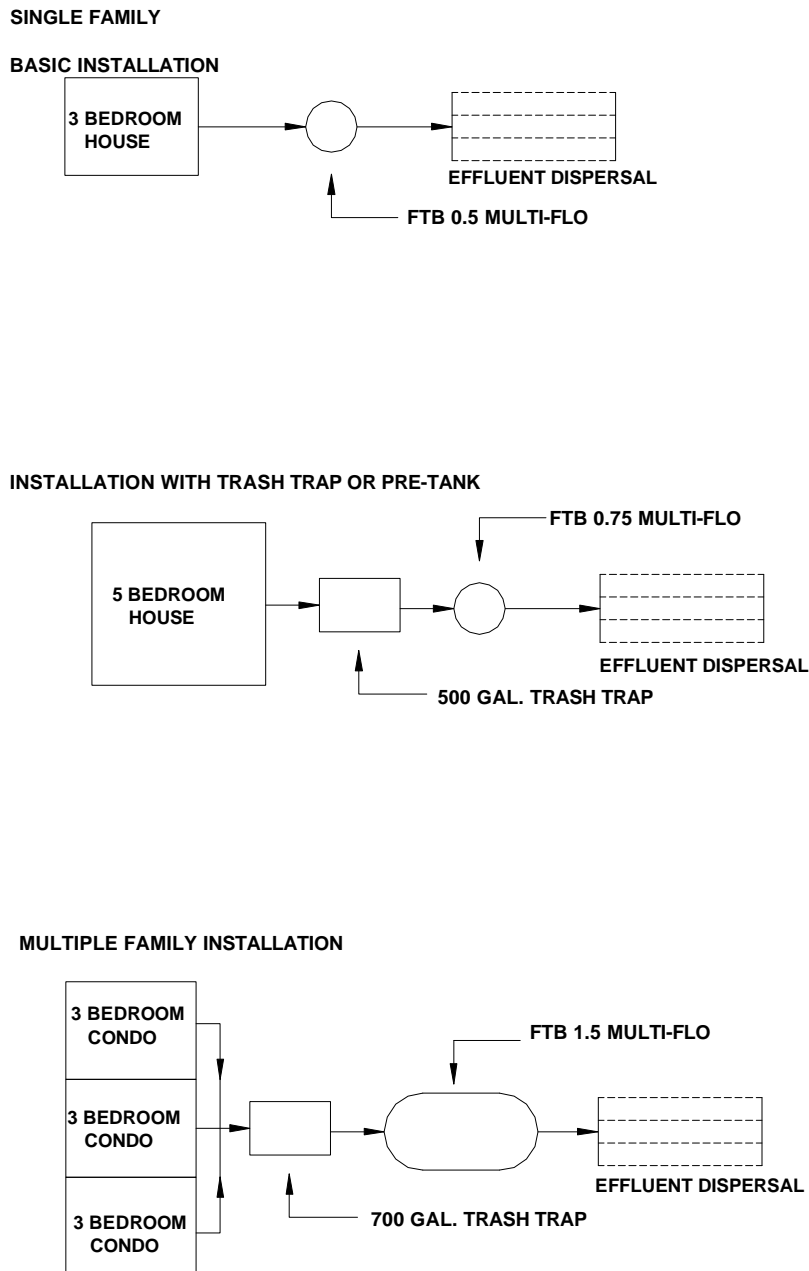

Figure 12—Examples 1, 2, & 3

Example 4: Commercial Occupancy, Office Buildings—Office buildings are designed based on the number of employers, frequenters, and based upon the presence of foodservice facilities. Figure 13 shows a layout of an office building that does not possess foodservice facilities. In designing a system for an office building, consideration must be made for the fact that the design flow may be generated within an 8-to-10 hour period. Thus, flow equalization may be essential to address surges into the Multi-Flo unit. Figure 13 illustrates two typical office building layouts.

Table 10—Example 4 Information	
Parameter	Value
Hydraulic Loading	20-25 Gal/Employee 20-25 Gal/Parking Space
Organic Loading	.04 Lb CBOD ₅ /Employee (240 mg/L CBOD ₅)
Grease Trap	Not Required
Trash Trap	500 Gallon
Pre-Aeration:	Not Required
Flow Equalization	Recommended

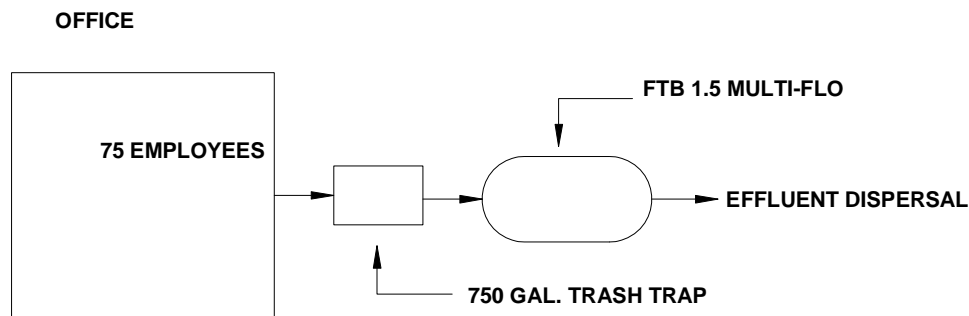
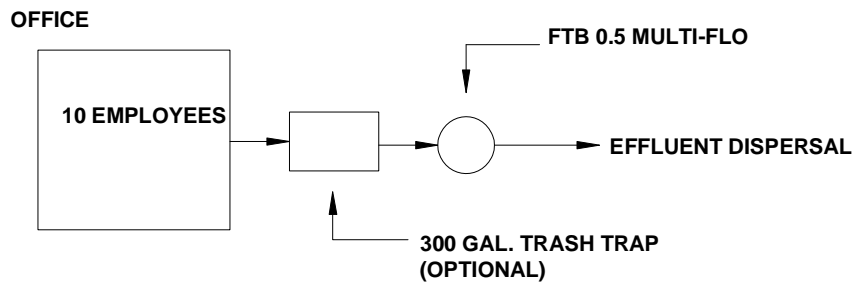

Figure 13—Example 4

Example 5: Commercial Occupancy, Retail Shopping Center Without Foodservice—Retail space wastewater flow is generally calculated based on the number of employees and number of frequenters. Often, the number of frequenters is estimated from the area of retail space.

Table 11—Example 5 Information	
Parameter	Value
Hydraulic Loading	(Retail Sales) 0.1 gal per sq. foot (Office Space) 20-25 gal per employee
Organic Loading	Retail Sales: .3 lb BOD per 1000 sq ft of floor space Office Space: .04 lb BOD per employee
Grease Trap	Not Required
Trash Trap	750 Gallon
Pre-Aeration:	Not Required
Flow Equalization	Recommended

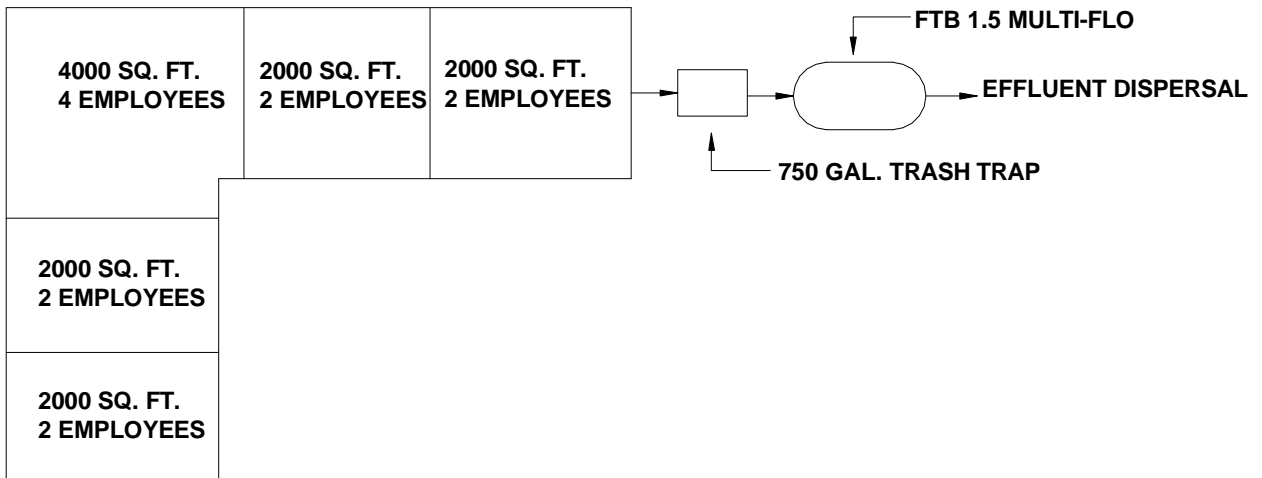

Figure 14—Example 5

Example 6: Commercial Occupancy, With Retail Shopping Plaza With Food Service/Laundry—It is important to provide adequate treatment (and pre-treatment) capacity for this type of facility. The initial design should indicate whether or not a food service or laundromat is proposed so that the Multi-Flo system can be properly designed. Failure to properly design the treatment system will probably result in a system failure when the food service or laundromat is added.

Table 12—Example 6 Information		
Parameter	Value	Total
Hydraulic Loading	20,000 sq. ft. @ 0.1 gal/sq.ft.	2000 gal.
	20 seat restaurant @50 gals/seat	1000 gal.
	6 machine laundromat @ 400 gal/machine	2400 gal.
		5400 gal/day
Organic Loading	BOD of 600-800 mg/L for new facility	
	Example 20,000 sq.ft.@0.03 lb/BOD/1000 sq.ft.	6.0 lb BOD
	20 seats(restaurant) @0.35 lb BOD/seat	7.0 lb BOD
	washing machines @ 2.0 lb BOD/machine	12.0 lb BOD
		24.4 lb/day
Grease Trap	required	
Trash Trap	required: min. capacity of 2700 gal.	
Anticipated Service Requirements	routine inspection	1-2 months
	pumping	6-12 months
	filter cleaning	3-12 months

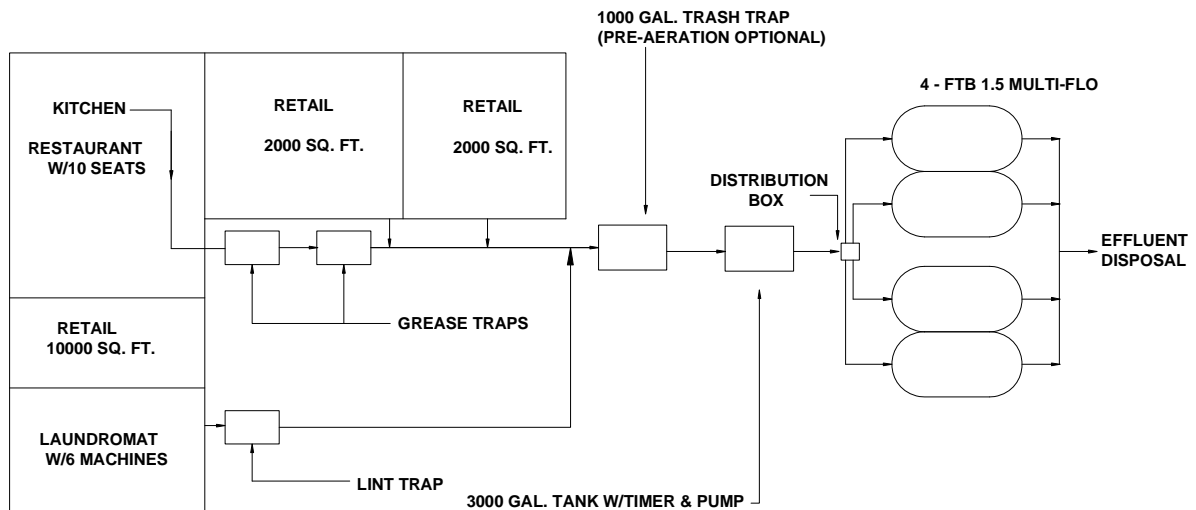

Figure 15—Example 6

Example 7: Commercial Occupancy—Mobile Home Park—Mobile home parks are usually characterized by relatively low (100 – 200 gpd) wastewater flows from each mobile home. For this reason, it is advisable, as well as cost effective, to group several mobile homes on one Multi-Flo system.

Table 13—Example 7 Information		
Parameter	Value	Total
Hydraulic Loading	1400 gal./day	
Organic Loading	0.40 lb BOD per space per day	
Pre-aeration	not required	
Flow equalization	not required unless there is a separate laundry building	
seeding for start-up	not required	
Anticipated Service Requirements	routine inspection	3-6 months
	pumping	1-2 years
	filter cleaning	1-2 years

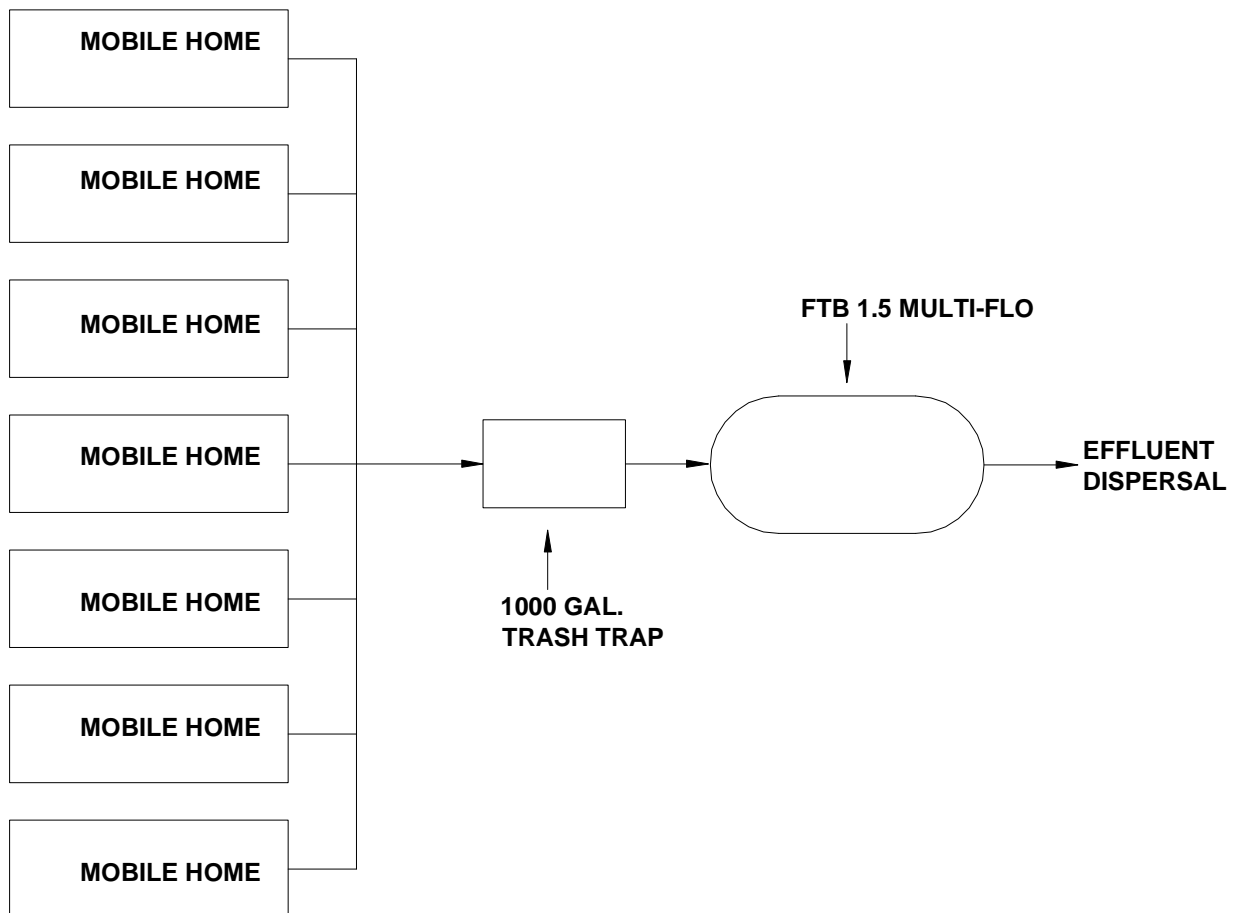

Figure 16—Example 7

Example 8: Commercial Occupancy—Institution—Institutional facilities present several problems that must be addressed in the total design. Depending upon the type of facility involved, consideration must be given to possible food service, laundry facilities, showers, as well as high water usage and heavy peak flow periods.

Parameter	Value	Total
Hydraulic Loading	hospital	200 gal/bed
	nursing home	100 gal/bed
	school	15 gal/student
	employee	20 gal/person
	kitchen	5 gal/person
	showers	5 gal/student
	laundry	400 gal/machine
Organic Loading	hospital	0.7 lb BOD/day per bed
	nursing home	0.3 lb BOD/day per bed
	school	0.03 lb BOD/day per student
	employee	0.04 lb BOD/day per employee
	kitchen	0.03 lb BOD/day per meal
	showers	0.01 lb BOD/day per student
	laundry	2.0 lb BOD/day per machine
grease trap	required	
trash trap	required	3,000 gal.
Pre-aeration	required if oxygen requirements exceed the capacity of the Multi-Flo unit	
Flow equalization	"	
seeding for start-up	"	
Anticipated service requirements	routine inspection	monthly
	pumping	6-12 months
	filter cleaning	6-12 months

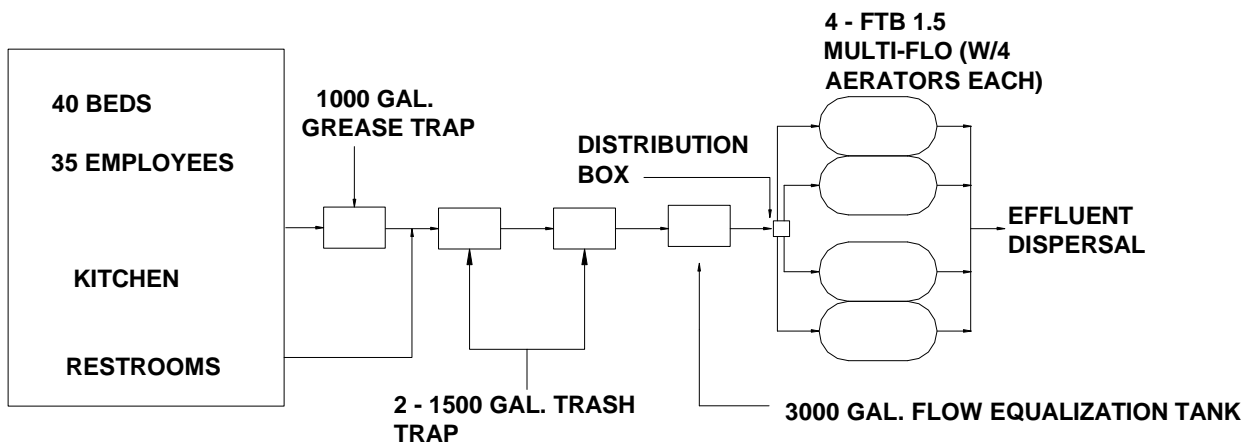

Figure 17—Example 8